

Technical specifications



EXCAVATORS 20 - 45 T (44,100 - 99,200 Lbs)

PA SERIES AUGERS 300mm-1.8M (12 in. - 71 in.) Dia

- Torque Range: 24,612 - 42,387 Nm (18,151-31,260 ft-lb)
- Oil Pressure Range: 180-310 Bar (2,611-4,496 psi)
- Oil Flow Range: 80-225 lpm (21 - 59 gpm)
- Speed Range: 9-26 rpm
- Unit Weight: 442 kg (974 lbs)
- Output Shaft Std: 110mm (4.33") Square
- Output Shaft Opt: 100mm (3.94") Square
130mm (5.125") Square

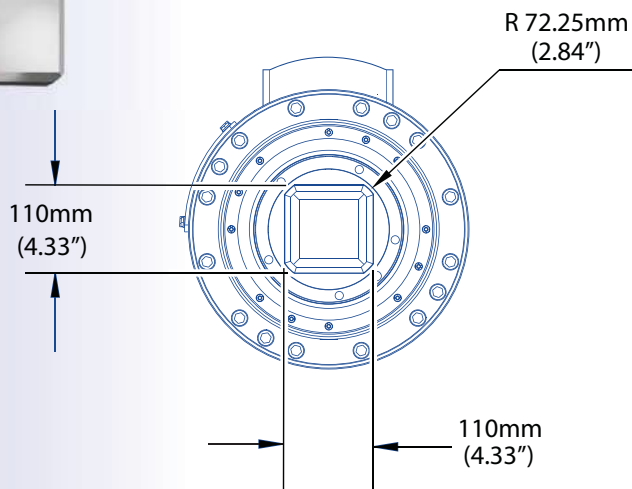
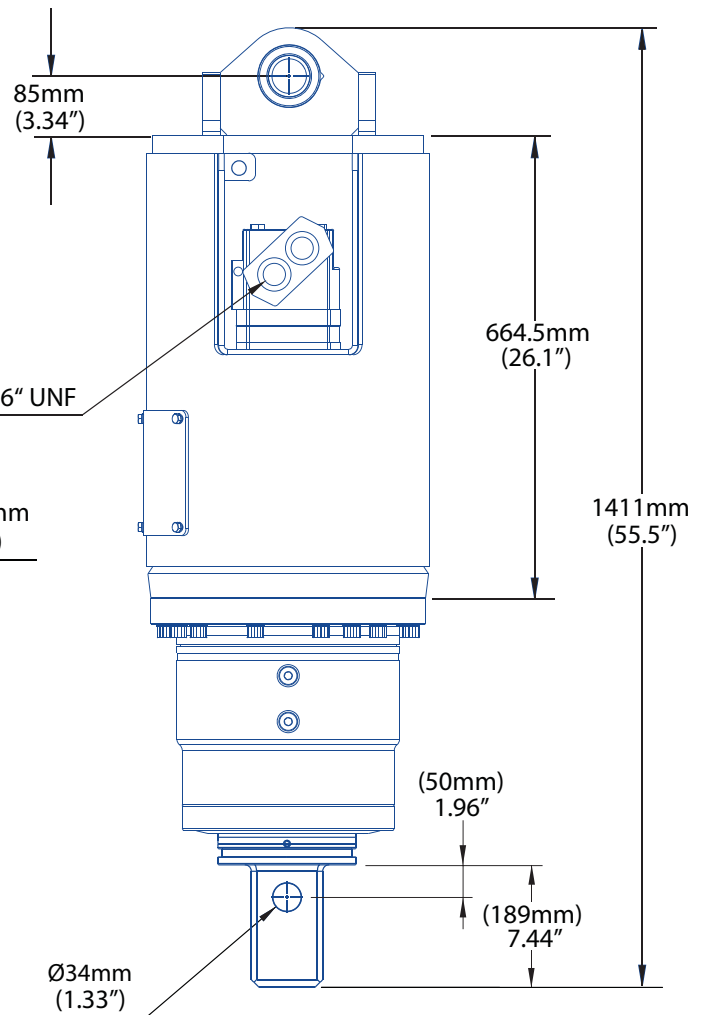
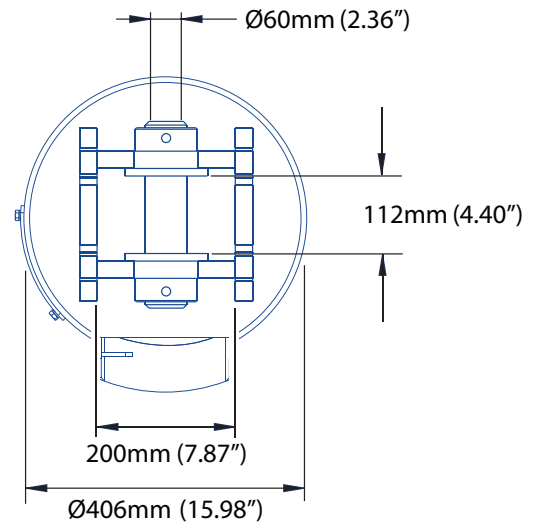

42000MAX

Earth Drill Flow versus Speed Output

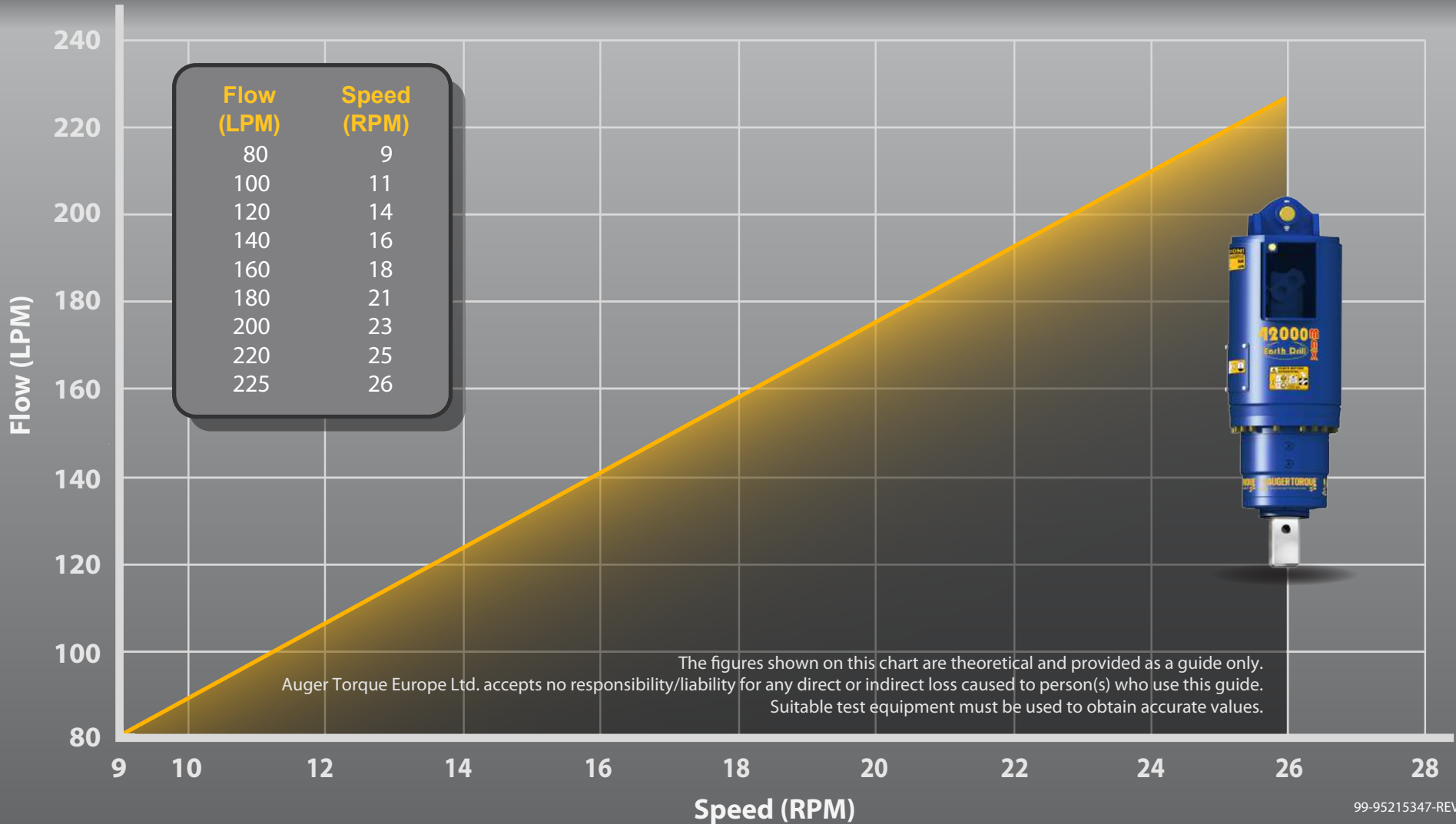

42000MAX

Earth Drill Pressure versus Torque Output

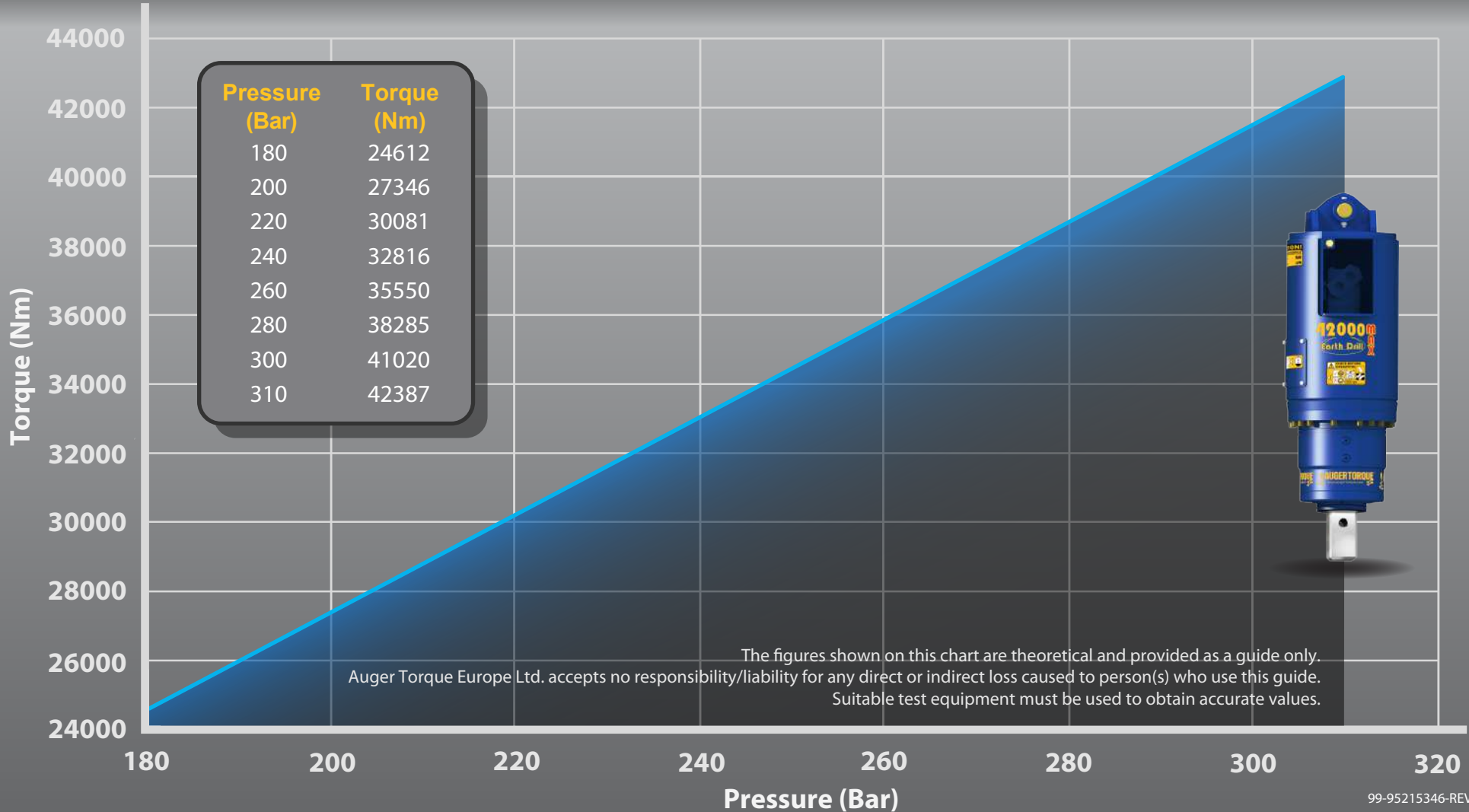

Case Drain Hose Fitting

40,000MAX

